

Output power characteristic of WEC for a buoy[†]

Jin-Seok Oh^{1,*}, Jun-Ho Kwak¹, Soo-Young Bae¹, Ji-Yeoung Lee² and Toshimitsu Komatsu³

¹*Division of Mechatronics Engineering, Korea Maritime University, Dongsam-dong 1, Youngdo-gu, Busan 606-791, Korea*

²*Department of Manufacturing Engineering, Cardiff University, The Parade, Newport Road, Cardiff, United Kingdom*

³*Department of Civil Engineering, Kyushu University, Kyushu, Japan*

(Manuscript Received July 4, 2008; Revised December 26, 2008; Accepted April 9, 2009)

Abstract

Floating devices, such as a cavity resonance device, take advantage of both the water motion and the wave induced motions of the floating body itself. In the design of a wave energy converter (WEC), the most significant factor is that an optimum length of the internal water column should exist, that is, a length in which maximum power is converted near the heaving resonance. A theoretical analysis of this power generated by a pneumatic-type WEC is performed, and the results obtained from the analysis are used for a real WEC for a buoy. The length of the internal water column corresponds to that of the water mass in the water column. If designed properly, a WEC can take advantage not only of the cavity resonance but also of the heaving motion of the buoy. This paper presents the test results of the generation characteristic of a WEC and the harmful effect of fouling in the internal water column. The results are then applied to the design of a WEC for a buoy.

Keywords: WEC; Resonance; Fouling

1. Introduction

This paper suggests the power increment method of a WEC with system modification and analyzes the output power characteristic of a WEC for a buoy. Out in the sea, a WEC is subjected to waves of varying heights and periods. It is essential that a WEC is provided for optimum control of the oscillatory motion in order to achieve maximum power conversion. Furthermore, the output power is influenced by marine life like barnacles and mussels because the internal water column in the buoy is blockaded by marine life. In the most extreme cases, the internal surface of the water column can become blocked, affecting the generation efficiency and heaving characteristic.

To obtain maximum energy from the waves, it is necessary to have optimum oscillation of the WEC. The

normal modes of oscillation are a function of several parameters such as the mass, wave height, period, heaving motion, and surface condition of the water column [1].

Fig. 1 shows the schematic diagram of the WEC for a buoy. The WEC for a buoy consists of a circular floatation body which contains a vertical water column that has free communication with the sea. The air above the internal free surface has a relative motion to the buoy caused by both the moving water surface and the heaving of the buoy. The mechanism utilizes the relative air motion above the internal free-surface to drive a turbine for the generator [2].

The conversion efficiency of the WEC ultimately depends on the air turbine design, and the output power is influenced by the surface condition of the water column. This type of WEC is used in navigation aids like buoys for ocean traffic systems.

This paper describes the output power characteristic of a WEC, along with the design condition of the internal water column and the fouling problem of marine life.

[†] This paper was recommended for publication in revised form by Associate Editor Jae Young Lee

*Corresponding author. Tel.: +82 51 410 4283, Fax.: +82 51 410 4283
E-mail address: ojs@hhu.ac.kr

© KSME & Springer 2009

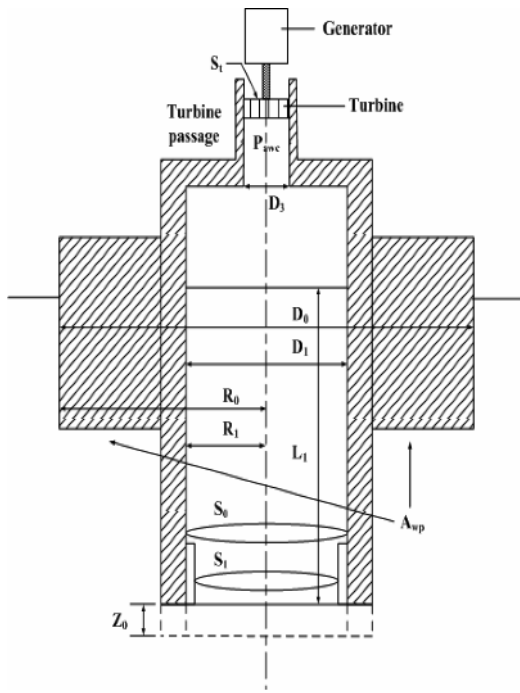

Fig. 1. Schematic diagram of the WEC for a buoy.

2. WEC characteristic

It is essential that a WEC is provided for optimum control of the oscillatory motion to achieve maximum power conversion. In an oscillator such as a WEC, the normal modes of oscillation are a function of several parameters such as the mass and heaving motion. If the wavelength is smaller than the characteristic length of the cross section of the water column, then an odd or even number of waves can occur within the water column. When the number of waves is even, the integrated power output is zero. If the number is odd, a peak occurs in the power curve. When the wavelength is greater than the characteristic length, the power is obtained from a single wave. In this paper, the maximum power is obtained at the resonant period of wave T_{rv} as Eq. (1).

$$T_{rv} = 2\pi \sqrt{\frac{L_1 + L_a}{g}} \tag{1}$$

where L_1 is the still water length of the water column; L_a is the effective length due to the added mass excited by the water column; and g is the gravitational acceleration. The heaving resonant period of a floating body T_{rb} is given by

$$T_{rb} = 2\pi \sqrt{\frac{m + m_a}{\rho_w g A_{wp}}} \tag{2}$$

where m is the mass of heaving system; m_a is the added mass, ρ_w is the mass density of seawater ($1,025 \text{ kg/m}^3$); and A_{wp} is the water plane area of the float. By using the resonance conditions, we can extract the design condition as $T_{rv} = T_{rb}$

The added mass excited by the heaving circular floatation body is

$$m_a = K \rho_w \pi (R_0^3 - R_1^3) \tag{3}$$

where K is a numerical coefficient corresponding to the buoy geometry. The mass with the water column length is increased by the pipe material and the water mass. The optimum design of the buoy is such that the water mass in the center pipe is approximately 2/3 of the buoy mass and the added mass combined. If the mass remains unchanged, the peak power increases indefinitely with L_1 . The increase in mass, however, will limit the power increase. Therefore, there should be a particular value for L_1 which is optimum. The design mass value of a body is given by

$$m = \frac{\pi}{4} (D_0^2 - D_1^2) \rho_w L_1 - m_a \tag{4}$$

where D_0 is the outer diameter of the float, and D_1 is the inner diameter. We retain the dimensions in Eq. (7) as originally used and simply change the mass “ m ” of the system by adding ballast [2]. If designed properly, this application can take advantage of not only the cavity resonance but also of the heaving motion of the buoy. By using the resonance conditions, we can extract the design conditions as

$$L_1 + L'_1 = \frac{4(m + m_a)}{\rho_w \pi (D_0^2 - D_1^2)} \tag{5}$$

where L'_1 is an effective length due to the added mass excited by the water column. To optimize the design of this buoy system, we use the design condition given in Eq. (5).

A peak value in the time-averaged power changes with the water column length L_1 . To determine the condition for this peak, a derivative, with respect to L_1 and R_1 of the expression in Eq. (6) is set equal to zero, while assuming the ideal situation of zero internal resistance [3-6].

$$\frac{dW}{dt} = \rho_a \dot{\xi} \left\{ \pi R_1^2 g \left[\frac{-\rho_w}{r_a} (L_1 + \xi) \ddot{\xi} + \frac{1}{g} \xi \ddot{\xi} \right] \right\} \quad (6)$$

where W is the power available to the turbine; ρ_a is the air density; and r_a is the specific weight of air. The L_1 -variation, therefore, can be attributed to the variation of the mass ratio. $\dot{\xi}$ is the difference between the average internal free-surface displacement and heaving displacement.

Furthermore, the maximum time-averaged power varies with the wave height. The maximum values of power occur at different periods for the length as the natural frequency of the water column and buoy system changes with the length. It should be noted that the internal free surface motion is very small at the lower peak. Thus, the power generated at the low period peak is primarily due to the heaving motion of the buoy [3-6].

Furthermore, the power changes with the macro fouling in the water column. The fouling problem arises when barnacles, mussels, and other lower forms of marine life enter the water column as larval. The pressure and inflow seawater flow quantity of the internal water column in the WEC is given by Eqs. (7) to (9).

$$Q_w = S_0 \cdot Z_0 \cdot \omega \cos(\omega t) \quad (7)$$

$$Q_{wml} = \frac{S_1}{S} \cdot \frac{T}{T_1} \cdot Q_{wm} \quad (8)$$

The maximum inflow seawater $S_0 \cdot Z_0 \cdot \omega$ is from Eq. (7), where Z_0 is the distance of heaving motion of the WEC.

$$P_{avl} = \frac{1}{2} \cdot \rho_a \cdot \frac{1}{\eta_n} \cdot \frac{1}{1-r} \cdot \frac{1}{S_t^2} \cdot (Q_{wml})^2 \quad (9)$$

where ρ_a is the air density; η_n is the nozzle efficiency; r is the turbine reaction coefficient; S_t is the cross section area of the turbine; T_1 is the period of the buoy with the fouling problem; T is the period of the buoy without the fouling problem; S_0 is the cross section area of the water column; S_1 is the cross section area of the water column in fouling condition; Q_{wm} is the maximum inflow seawater in the water column [7-9].

3. Simulation

The peak power changes with the water column length L_1 and the inner diameter D_1 . The design condition for

a WEC is decided by the water column length and the inner diameter of the water column. Fig. 2(a) presents the relation of the output power and the water column dimension.

The effect of the variation of the water column length L_1 and the inner diameter D_1 on the peak power is presented in Fig. 1(b).

The peak power occurs when $L_1 \cong 6.2$ m. To determine the condition for this value, a derivative with respect to L_1 of the expression in Eq. (6) is set equal to zero, while assuming the ideal situation of zero internal resistance. From Eq. (5), the water column length variation can be influenced by the variation of the mass. With the increase in the water column length L_1 , the buoy

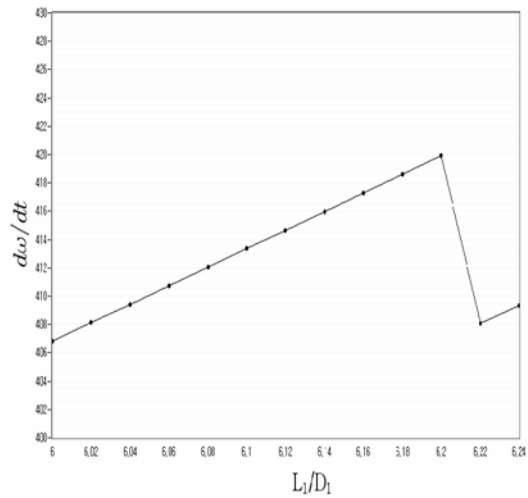

(a) Output power with L_1

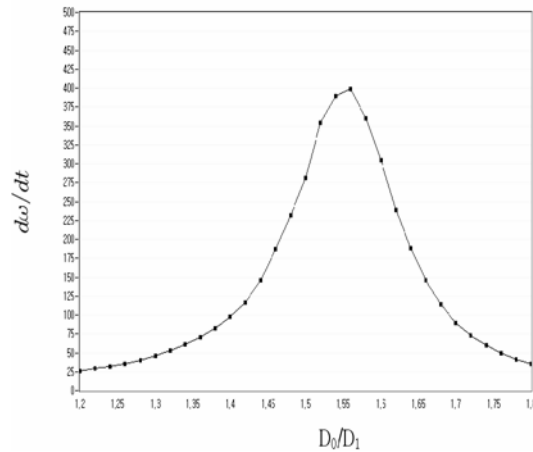

(b) Output power with D_1

Fig. 2. Output power with L_1 and D_1 .

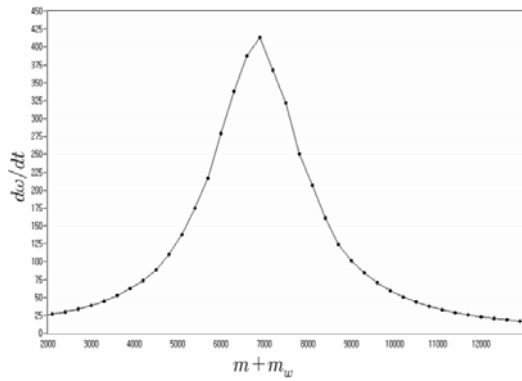

Condition: Water column length = 6.2m

Fig. 3. Power variation with the water column mass.

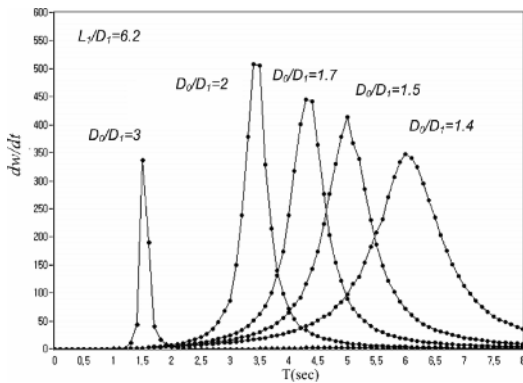

Fig. 4. Output power with the ratio of D_0 / D_1 and L_1 / D_1 .

mass increases in two ways. First, there is the obvious increase in the water column material. Second, there is an increase in the water mass affected. If the mass remains unchanged, the peak power increases indefinitely with L_1 .

The increasing mass in Fig. 3, however, will limit the power increase. Therefore, there should be a particular value for L_1 which is optimum. For lengths greater than this optimum value, the power will be reduced.

The output power is influenced by the ratio of D_0 / D_1 and L_1 / D_1 with the test results presented in Fig. 4. The maximum power values occur at different periods and ratios (D_0 / D_1 and L_1 / D_1). From Fig. 4, we can see that the wave frequency has a most significant effect on the maximum power values; therefore, the ratios will be decided according to the most generation wave frequency in the operating sea.

The buoy with hybrid power system is made according to the design theory of WEC for a buoy. The basic specifications of the buoy are illustrated in Table 1.

Table 1. Specifications of the test buoy.

Item	Specifications	Remark
Water Column length (L_1)	6.2 m	Fig. 2(a)
Mass of buoy system(m)	6,900 kg	Fig. 3
Weight of generation system	14 Kg	
Generated power	400 W or More	Fig. 2, 3, 4
Minimum wave height	0.5 m	-
Water column diameter (D_1)	1.04 m	Fig. 4
Turbine impeller Turbine passage diameter(D_3)	6 blades 0.25 m	Wells type
Output power type	3-phase AC	-

Table 2. Simulation results of the harmful effect of microorganisms.

Item	data				Remark
	0	0.05	0.1	0.15	
Thickness of micro organism (m)	0	0.05	0.1	0.15	Input
Inner diameter of buoy D_1 (m)	0.1	0.9	0.8	0.7	Input
Decreased cross sectional S_1 (m^2)	0.5027	0.3848	0.2827	0.1963	Input
Quantity of seawater Q_{wm} (m^3/s)	0.8887	0.6529	0.4534	0.2902	Output
Generation power (W)	430	83	20	5	Output
Energy ratio without micro organism	1.0	0.19	0.05	0.01	Output

As Table 2 shows, the generation power decreases with the macro fouling in the water column. An anti-fouling system is used to treat the harmful effects of lower forms of marine life in the water column of the WEC.

4. Conclusion

This resonance technique for a WEC is used in some commercially available buoys to power navigation aids such as lights. If designed properly, this application can take advantage not only of the resonance characteristic but also of the heaving motion of the buoy. A WEC is most effective for waves near the resonant period of the buoy and water column system. The mass increasing with the water column length will eventually result in the optimum length of the water column from which maximum power will be obtained near the heaving resonance period of the buoy. The increase in mass, however, will limit the power increase. Therefore, there should be a particular value for the wa-

ter column length, which is optimum. The generation efficiency of a wave generation system in a hybrid system is influenced by the fouling problem in the water column of a WEC. To resolve this problem, an anti-fouling system should be used.

Acknowledgments

This paper is based on “The development of a hybrid power generation system for ocean facility” supported by the Ministry of Land, Transport, and Maritime Affairs of Korea.

References

- [1] M. E. McCormick, Analysis of a wave energy conversion buoy, *Journal of Hydronautics* 8(3) (1974) 77-82.
- [2] A. Thakker, Z. Usmani and T. S. Dhanasekaran, Effects of turbine damping on performance of an impulse turbine for wave energy conversion under different sea conditions using numerical simulation techniques, *Journal of Renewable Energy* 29(14) (2004) 2133-2151.
- [3] M. E. McCormick, B. H. Carson and D. H. Rau, An experimental study of a wave energy conversion buoy, *Journal of Marine Technology Society* 9(3) (1975) 40-42.
- [4] M. E. McCormick, A modified linear analysis of a wave energy conversion buoy, *Journal of Ocean Engineering* 3(4) (1976) 133-144.
- [5] M. E. McCormick, *Ocean wave energy conversion*, Wiley-Interscience, New York, USA, (1981) 45-75.
- [6] A. F. de O. Falcao and R. J. A. Rodrigues, Stochastic modeling of OWC wave power plant performance, *Journal of Applied Ocean Research* 24(2) (2002) 59-71.
- [7] Y. Huang, M. Lwata, M. Usami and K. Ueda, A study on the antifouling technique through seawater electrolysis on structural surface, Proceedings of 9th International Offshore and Polar Engineering Conference (1999) 146-150.
- [8] X. Xiaokai, M. Chongfang and C. Yongchang, Investigation on the electric anti-fouling technology for scale prevention, *Journal of Chemical Engineering and Technology* 28(12) (2005) 1540-1545.
- [9] J. C. Cowan and D. J. Weingritt, Water-formed scale deposits, Gulf Publishing Company, Huston, USA, (1976)



Jin-Seok Oh was born in Kyung-Nam, Korea. He received the B. E. degree in Marine Engineering from Korea Maritime University in 1983. Since 1983, he has been with the Zodiac (England Company) including early 4 years of System Engineer. He received the

M.E. and Ph. D. degrees from Korea Maritime University, Busan, Korea in 1989 and 1996, respectively. He had been with the Agency for Defense Development (ADD) as a researcher from 1989 to 1992. In 1996, he joined the Division of Mechatronics Engineering at Korea Maritime University. His research interests include electrical drive systems, robot control and PC-based Control applications.